

Ahsanullah University of Science and Technology
Department of Electrical and Electronic Engineering

LABORATORY MANUAL
FOR
ELECTRICAL AND ELECTRONIC SESSIONAL COURSES

Student Name :

Student ID :

Course no : EEE - 1204

Course Title : Electronic Circuits - I Lab

For the students of
Department of Electrical and Electronic Engineering
1st Year, 2nd Semester

List of Experiments

Exp. No.	Experiment Name
1.	I-V characteristics of diode
2.	Diode rectifier circuits
3.	Clipper and clamper circuits
4.	Zener diode applications
5.	The output characteristics of CE (common emitter) configuration of BJT
6.	The BJT biasing circuits
7.	Frequency response of a CE (common emitter) amplifier circuit and measurement of input and output impedance
8.	The I-V characteristics of a n-channel enhancement type MOSFET
9.	Open Ended Lab

Experiment No: 1

Name of the Experiment : I-V Characteristics of diode.

Objective :

Study the I-V characteristic of diode.

Theory :

A diode is a bi-polar device that behaves as the short circuit when it is in forward bias and as an open circuit when it is in reverse bias condition.

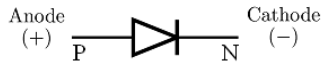

Figure 1.1 : Schematic Diagram of Diode.

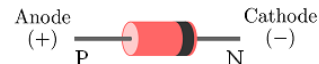

Figure 1.2 : P - N Junction Diode .

There are two types of biasing condition for a diode :

1. When the diode is connected across a voltage source with positive polarity of source connected to p side of diode and negative polarity to n side, then the diode is in forward bias condition.
2. When the diode is connected across a voltage source with positive polarity of source connected to n side of diode and negative polarity to p side, then the diode is in reverse bias condition.

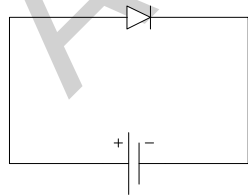

Figure 1.3 : Forward Bias connection.

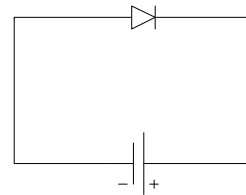

Figure 1.4 : Reverse Bias connection.

If the input voltage is varied and the current through the diode corresponds to each voltage are taken then the plot of diode current (I_d) vs diode voltage (V_D) will be follows :

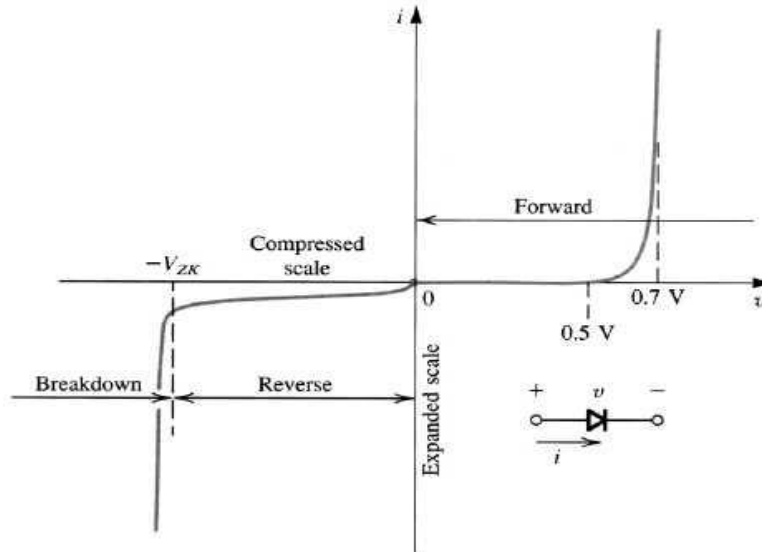

Figure 1.5 : I - V Characteristics of Diode.

At the reverse bias condition the amount of current flows through the diode is very small (at microampere range). But if the voltage continuously increases in reverse direction, at a certain value the diode will break down and huge amount of current will flow in reverse direction. This is called breakdown of diode. In laboratory the breakdown will not tested because it will damages the diode permanently.

From the characteristics curve it can be seen that, a particular forward bias voltage (V_f) is required to reach the region of upward swing. This voltage, V_f is called the cut-in voltage or threshold voltage of diode. For Si diode the typical value of threshold voltage is 0.7 volt and for Ge diode is 0.3 volt.

Equipments And Components :

Serial no.	Component Details	Specification	Quantity
1.	p-n junction diode	1N4007	1 piece
2.	Resistor	1 K Ω	1 piece
3.	DC power supply		1 unit
4.	Signal generator		1 unit
5.	Trainer Board		1 unit
6.	Oscilloscope		1 unit
7.	Digital Multimeter		1 unit
8.	Chords and wire		as required

Experimental Setup :

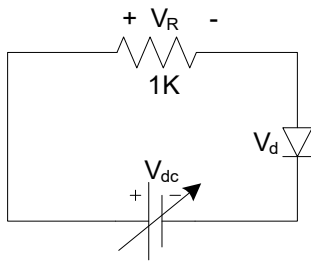

Figure 1.6 : Circuit Diagram for Obtaining Diode Forward Characteristics.

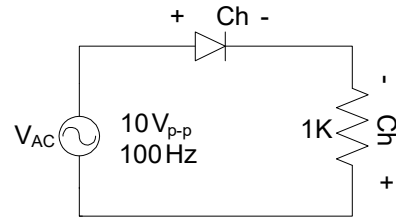

Figure 1.7 : Circuit Diagram for Obtaining Characteristics From Oscilloscope.

Procedure :

1. Measure the resistance accurately using multimeter.
2. Construct the circuit as shown in figure - 1.6.
3. Vary input voltage V_{dc} . Measure V_{dc} , V_d , V_R for the given values of V_d and record data on data table. Obtain maximum value of V_d without increasing V_{dc} beyond 25 volt.
4. Calculate the values of I_d using the formula, $I_d = V_R / R$.
5. Construct the circuit as shown in figure - 1.7.
6. Set the oscilloscope in X-Y mode. Identify zero record on oscilloscope display. Make proper connection and observe the output.
7. Repeat the step 5 and 6 by increasing the input supply frequency 5 KHz.

Data Table :

V_{dc} (volt)	V_d (volt)	V_R (volt)	$I_d = V_R / R$ (mA)

Report :

1. Draw the I - V characteristics curve of diode from the reading obtain in this experiment.
2. Calculate static resistance for $I_d = 5$ mA and $I_d = 10$ mA.
3. Determine the Q- point for the circuit in figure - 6, when $V_{dc} = 8$ volt.

Experiment No: 02

Name of the Experiment: Diode rectifier circuits.

Objective:

Study of different diode rectifier circuits.

Theory:

A rectifier converts an AC signal into a DC signal. From the characteristic curve of a diode we observe that it allows the current to flow when it is in the forward bias only. In the reverse bias it remains open. So, when an alternating voltage (signal) is applied across a diode it allows only the half cycle (positive half cycle depending on the orientation of diode in the circuit) during its forward bias condition, other half cycle will be clipped off. In the output the load will get DC signal.

Diode rectifier can be categorized in two major types. They are -

1. Half-wave rectifier.
2. Full-wave rectifier.

Half - Wave Rectifier: Half-wave rectifier can be built by using a single diode. The circuit diagram and the wave shapes of the input and output voltage of half wave rectifier are shown bellow (figure 2.1) -

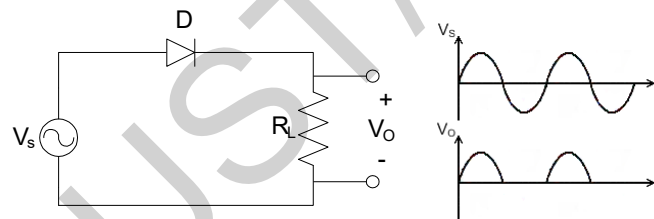

Figure 2.1: Half Wave Rectifier.

The major disadvantages of half wave rectifier are -

- In this circuit the load receives approximately half of input power.
- Average DC voltage is low.
- Due to the presence of ripple output voltage is not smooth one.

Full Wave Rectifier: in the full-wave rectifier both the half cycle is present in the output. Two circuits are used as full-wave rectifier are shown bellow -

- a) Full-wave rectifier using center-tapped transformer.
- b) Full-wave bridge rectifier.

Full-wave rectifier using center-tapped transformer: two diodes will be connected to the ends of the transformer and the load will be between the diode and center tap. The circuit diagram and the wave shapes are shown in bellow (figure 2.2) -

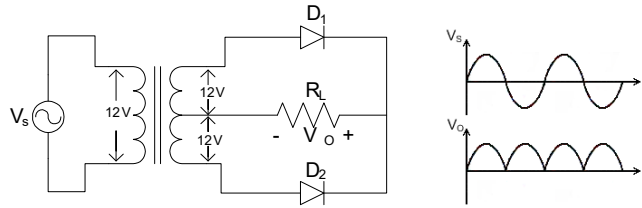

Figure 2.2: Full Wave Rectifier Using Center Tapped Transformer.

Full-wave rectifier using center-tapped transformer circuit has some advantages over full-wave rectifier. Those are -

- Wastage of power is less.
- Average DC output increase significantly.
- Wave shape becomes smoother.

The disadvantages of full-wave rectifier using center-tapped transformer are -

- Require more space and becomes bulky because of the transformer.
- Not cost effective (for using transformer).

Full-wave bridge rectifier: a bridge rectifier overcomes all the disadvantages of described above. Here four diodes will be connected as bridge connection. The circuit diagram and the wave shapes are shown in bellow (figure 2.3) -

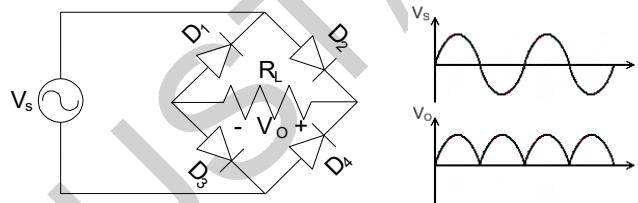

Figure 2.3: Full Wave Bridge Rectifier.

This rectifier however cannot produce a smooth DC voltage. It produces some ripple in the output. This ripple can be reducing by using filter capacitor across the load.

Equipments And Components:

Serial no.	Component Details	Specification	Quantity
1.	p-n junction diode	1N4007	4 piece
2.	Resistor	10KΩ	1 piece
3.	Capacitor	0.22μF, 10μF	1 piece each
4.	Signal generator		1 unit
5.	Trainer Board		1 unit
6.	Oscilloscope		1 unit
7.	Digital Multimeter		1 unit
8.	Chords and wire		as required

Experimental Setup:

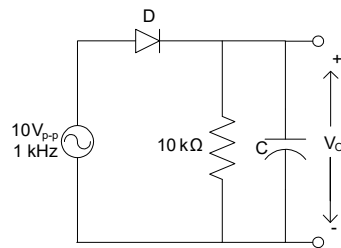

Figure 2.4 : Experimental Circuit 1.

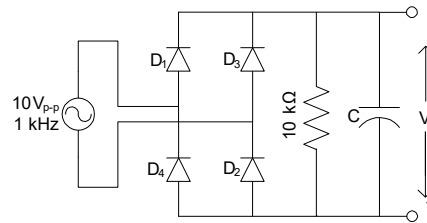

Figure 2.5 : Experimental Circuit 2.

Procedure:

1. Connect the circuit in breadboard as shown in figure 2.4 without capacitor.
2. Observe the output and input voltages in the oscilloscope and draw them.
3. Connect the $0.22\mu\text{F}$ capacitor and repeat step 2.
4. Connect the $10\mu\text{F}$ capacitor and repeat step 2. How does the output wave-shape differ from that in step 3?
5. Vary the frequency from 10 KHz to 100 Hz. What effects do you observe when frequency is changed?
6. Connect the circuit breadboard as shown in figure 2.5 without capacitor.
7. Observe the output and input voltages in the oscilloscope and draw them.
8. Connect the $0.22\mu\text{F}$ capacitor and repeat step 7.
9. Connect the $10\mu\text{F}$ capacitor and repeat step 7. How does the output wave-shape differ from that in step 8?
10. Vary the frequency from 10 KHz to 100 Hz. What effects do you observe when frequency is changed?

Report:

1. Write the answers that were asked during the working procedure.
2. Draw the input wave, output wave (without and with capacitor) for both the circuits.
3. What is the effect in output for changing input signal frequency for both the circuits (without and with capacitor)?
4. What is the function of capacitor in the both circuits? Why a capacitor of higher value is preferable?

Experiment No: 03

Name of the Experiment: Clipper and Clamper circuits.

Objective:

Study of Clipper and Clamper circuits.

Theory:

Clipper: Clippers remove signal voltage above and below a specified level. In the experiment no. 2, half wave rectifier can also be called as a clipper circuit. Because it clipped off the negative half cycle of the input signal.

A diode connected in series with the load can clipped off any half cycle of input depending on the orientation of the diode. (figure 3.1) -

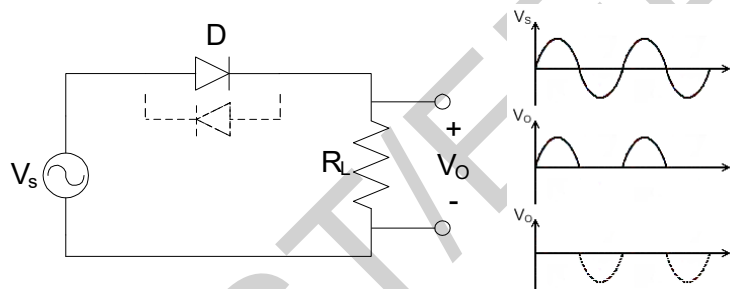

Figure 3.1: Simple Diode Clipper.

It is also possible to clip off a certain part of the input signal below a specified signal level by using a voltage source in reverse bias condition with the diode. If a battery of V volts is added to it, then for V_s above $(V+0.7)$ volts the diode becomes forward bias and turns ON. The load receives above this voltage level.

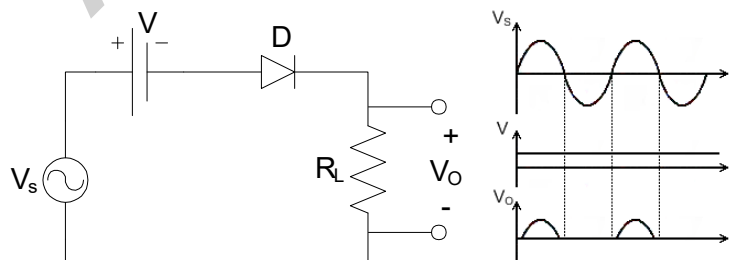

Figure 3.2: Clipper Circuit Using Bias Diode.

A diode connected in parallel with the load can clip off the input signal above 0.7 volts of one half cycle depending on the connection of the diode. Using two diodes in parallel in opposite direction both the half cycle can be limited to 0.7 volts.

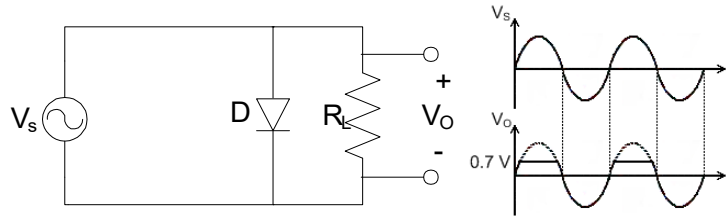

Figure 3.3: Parallel Clipper Circuit.

Using a biased diode it is possible to limit the output voltage to a specified level depending on the attached battery voltage. Either the half cycles or both of them can be clipped off above a specified level.

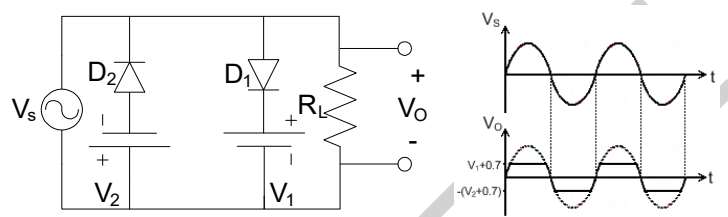

Figure 3.4: Biased Parallel Clipper Circuit.

In practical case for both the series and parallel clippers voltage source is not added. Required voltage levels are maintained by adding more semiconductor diode.

Clamper: A DC clamper circuit adds a DC voltage to the input signal. For instance, if the incoming signal varies from -10 volts to +10 volts, a positive DC clamper will produce an output that ideally swing from 0 volts to 20 volts and a negative clamper would produce an output between 0 volts to -20 volts.

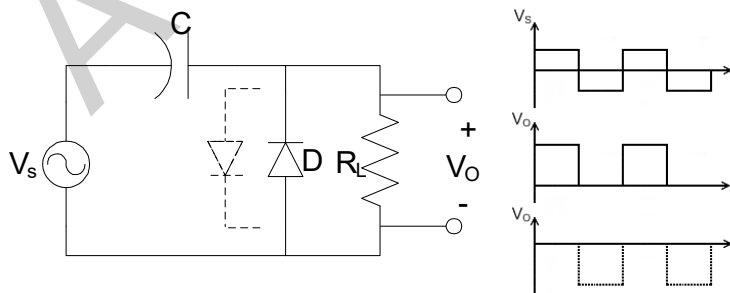

Figure 3.5: Clamper Circuit.

Equipments And Components :

Serial no.	Component Details	Specification	Quantity
1.	p-n junction diode	1N4007	1 piece
2.	Resistor	100K Ω	1 piece
3.	Capacitor	0.1 μ F	1 piece
4.	Signal generator		1 unit
5.	Trainer Board		1 unit
6.	DC power Supply		1 unit
7.	Oscilloscope		1 unit
8.	Digital Multimeter		1 unit
9.	Chords and wire		as required

Experimental Setup:

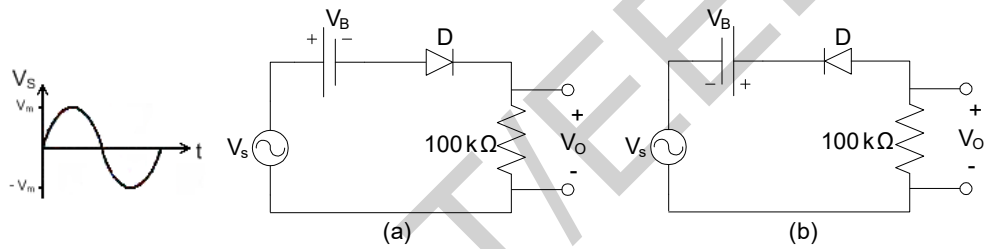

Figure 3.6: Experimental Circuit 1.

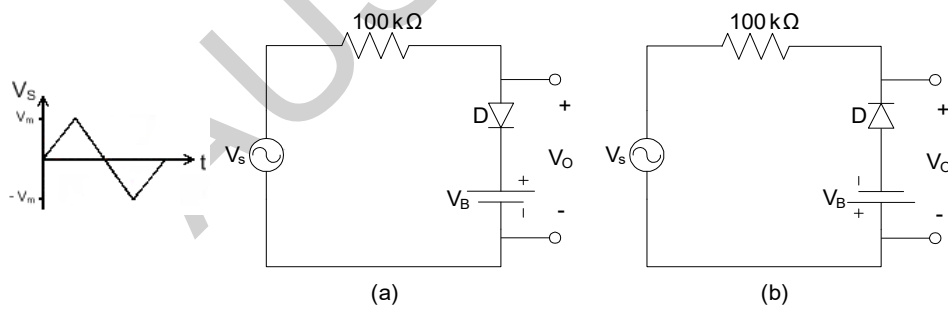

Figure 3.7: Experimental Circuit 2.

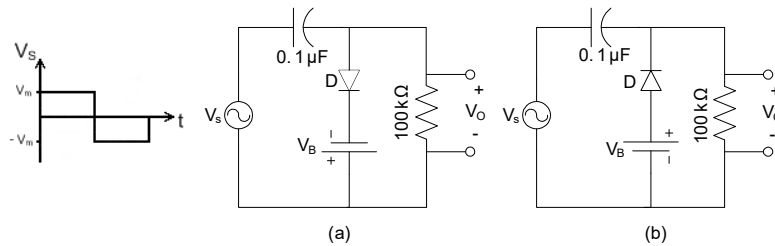

Figure 3.8: Experimental Circuit 3.

Procedure :

1. Connect the circuit as shown in the figure 3.6. Using a sinusoidal voltage source with 5 volts peak (V_m).
2. Observe the output wave shapes for various values of V_B and draw $V_B = 2.5$ volts for each circuit..
3. Do the same as in step 1 and 2 for the circuits in figure 3.7 with V_s wave shapes as drawn beside each figure having $V_m = 5$ volts. Parallel Branch 1 of circuit of figure 3.7(a) and Branch 2 of circuit of figure 3.7(b) and observe output.
4. For the clamper circuits of figure 3.8 do the same steps as step 1 and 2 with V_s wave shapes as drawn beside each figure having $V_m = 5$ volts.

Report :

1. Sketch all the waveforms observed on the oscilloscope.
2. What role dose the value of capacitor used in the clamping circuit play in order to obtain proper clamping?
3. Add the SPICE simulation waveforms of all the experimental circuits.

Experiment No : 04

Name of the Experiment : Zener Diode applications.

Objective:

Study of the Zener Diode applications.

Theory :

The diodes we have studied before do not operate in the breakdown region because this may damage them. A Zener diode is different; it is a silicon diode that the manufacturer has optimized for operation in the breakdown region. It is used to build voltage regulator circuits that circuits that hold the load voltage almost constant despite large change in line voltage and load resistance. The symbol of Zener diode shows in figure 4.1.

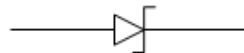

Figure 4.1 : Symbol of Zener Diode.

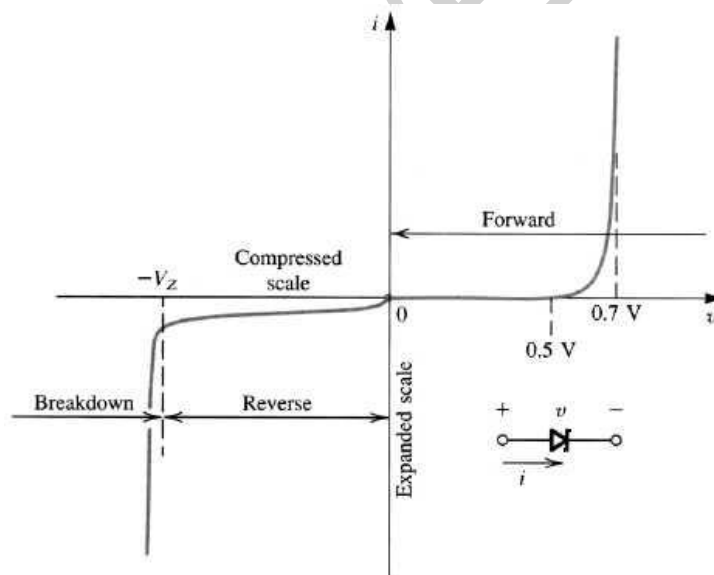

Figure 4.2 : I - V Characteristics of Zener Diode.

The Zener diode may have a breakdown voltage from about 2 to 200 volts. These diodes can operate in any of three regions – forward, leakage and breakdown. Figure 4.2 shows the I-V characteristics curve of Zener diode.

- In the forward region it works as an ordinary diode.
- In the leakage region (between zero and breakdown) it has only a small reverse saturation current.
- In the breakdown it has a sharp knee, followed by an almost vertical increase in current without changing the voltage.
- The voltage is almost constant, approximately equal to V_z over most of the breakdown region.

Equivalent circuits of Zener Diode : Two approximation are used for Zener Diode equivalent circuit.

First Approximation : As the voltage remains constant across the Zener diode though the current changes through it, it is considered as a constant voltage source according to the first approximation.

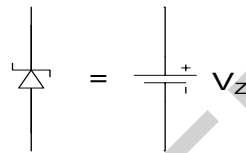

Second Approximation : A Zener resistance is in series with the ideal voltage source is approximated.

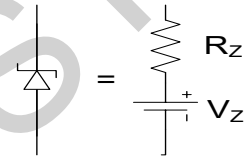

Equipments and Components:

Serial no.	Component Details	Specification	Quantity
1.	Zener diode	5 volts	1 piece
2.	Resistor	220Ω, 470Ω, 1KΩ	1 piece each
3.	POT	10KΩ	1 unit
4.	Trainer Board		1 unit
5.	DC Power Supply		1 unit
6.	Digital Multimeter		1 unit
7.	Chords and wire		as required

Experimental Setup:

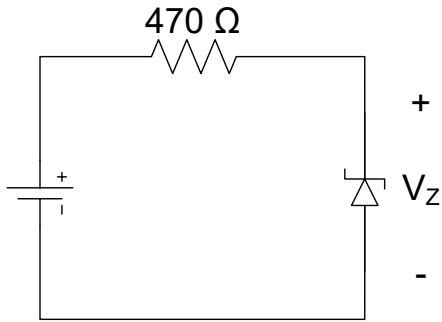

Figure 4.3 : Experimental Circuit 1.

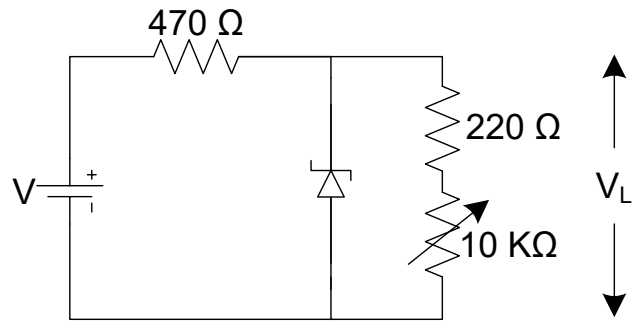

Figure 4.4 : Experimental Circuit 2.

Procedure :

1. Connect the circuit as shown in the figure 4.3
2. Vary the supply voltage from zero volt, complete the Table 4.1.
3. Connect the circuit as shown in the figure 4.4
4. Keep the POT at maximum position and power up the circuit. Apply 10 as V.
5. Gradually decrease the POT resistance and complete the Table 4.2.
6. Replace load with 1KΩ resistance, vary the supply voltage and take reading for Table 4.3.

Table 4.1 : Data for I - V characteristics.

V (volts)	V_R (volts)	V_z (volts)	$I_z = V_R / R$ (mA)
1.0			
2.0			
3.0			
4.0			
5.0			
6.0			
7.0			
8.0			
9.0			
10.0			
11.0			
12.0			

Table 4.2 : Data for regulation due to load variation.

V_{220} (mV)	V_L (volts)	I_L (Amp)

Table 4.3 : Data for regulation due supply voltage variation.

V (volts)	V_L (volts)
5.0	
6.0	
7.0	
8.0	
9.0	
10.0	
11.0	
12.0	

Report :

1. Plot the I - V characteristics of Zener diode. Determine the Zener breakdown voltage from the plot.
2. Plot I_L vs V_L for the data table 4.2. Find the voltage regulation.
3. Plot V_L vs V for the data table 4.3. Find the voltage regulation.

Experiment No: 05

Name of the Experiment : The output characteristics of CE (common emitter) configuration of BJT.

Objective:

Study of the output characteristics of CE (common emitter) configuration of BJT.

Theory :

Unlike the diode, which has two doped region, a transistor has three doped region. They are as follows –

- a) Emitter,
- b) Base and
- c) Collector.

These three doped regions form two junctions: One between the emitter and base and other between the collector and the base. Because of these it can be thought as combination of two diodes, the emitter and the base form one diode and the collector and base form another diode. The emitter is heavily doped. Its job is to emit or inject free majority carrier (electron for NPN and hole for PNP) into the base. The base is lightly doped and very thin. It passes the most of the emitter-injected electron (for NPN) into the collector. The doping level of the collector is between emitter and base. Figure 5.1 shows the biased NPN transistor.

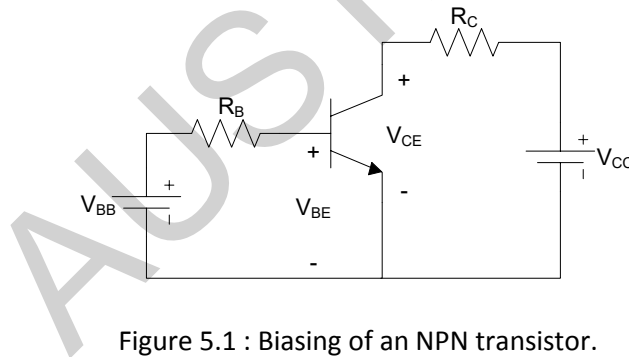

Figure 5.1 : Biasing of an NPN transistor.

If the V_{BB} is greater than the barrier potential, emitter electron will enter base region. The free electron can flow either into the base or into the collector. As base lightly doped and thin, most of the free electron will enter into the collector.

There are three different current in a transistor. They are emitter current (I_E), collector current (I_C) and the base current (I_B) are shows in figure 5.2.

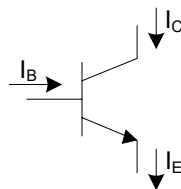

Figure 5.2 : Different current in transistor.

Here, $I_E = I_C + I_B$, and the current gain $\beta = \frac{I_C}{I_B}$

Characteristics Curve : The characteristics of a transistor is measured by two characteristics curve. They are as follows –

- Input characteristics curve.
- Output characteristics curve.

Input Characteristics Curve : Input characteristics is defined as the set of curves between input current (I_B) vs. input voltage (V_{BE}) for the constant output voltage (V_{CE}). It is the same curve that is found for a forward biased diode.

Output Characteristics Curve : Output characteristics is defined by the set of curves between output current (I_C) vs. output voltage (V_{CE}) for the constant input current (I_B). The curve has the following features –

- It has three regions namely Saturation, Active and Cutoff region.
- The rising part of the curve, where V_{CE} is between 0 and approximately 1 volt is called saturation region. In this region the collector diode is not reversed biased.
- When the collector diode of the transistor becomes reverse biased, the graph becomes horizontal. In this region the collector remains almost constant. This region is known as the active region. In applications where the transistor amplifies weak radio and TV signal, it will always be operation in the active region.
- When the base current is zero, but there is some collector current. This region of the transistor curve is known as the cutoff region. The small collector current is called collector cutoff current.
- For different value of base current (I_B) an individual curve can be obtained.

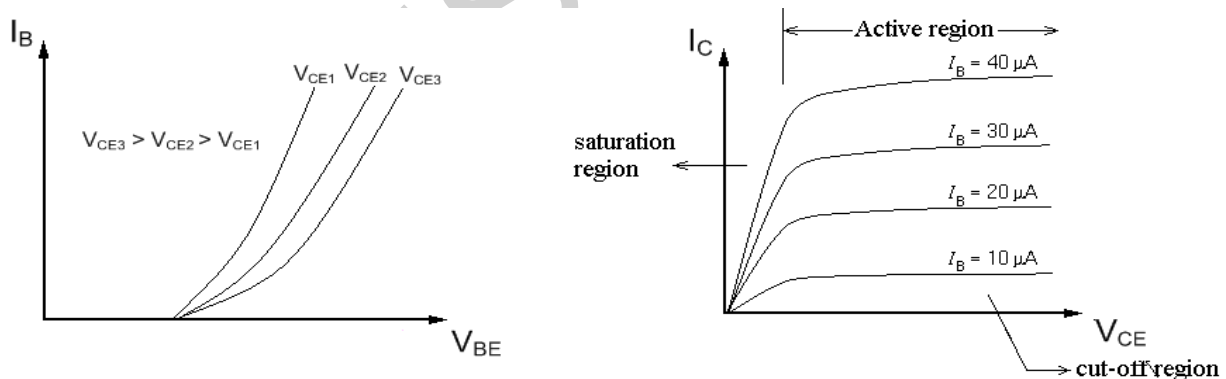

Figure 5.3 : (a) Input Characteristic, (b) Output Characteristic of NPN transistor.

Equipments And Components:

Serial no.	Component Details	Specification	Quantity
1.	Transistor	C828	1 piece
2.	Resistor	470Ω, 2.2KΩ, 3.3KΩ, 4.7KΩ, 10KΩ, 470KΩ	1 piece each
3.	POT	100KΩ	1 unit
4.	Trainer Board		1 unit
5.	DC Power Supply		1 unit
6.	Digital Multimeter		1 unit
7.	Chords and wire		as required

Experimental Setup:

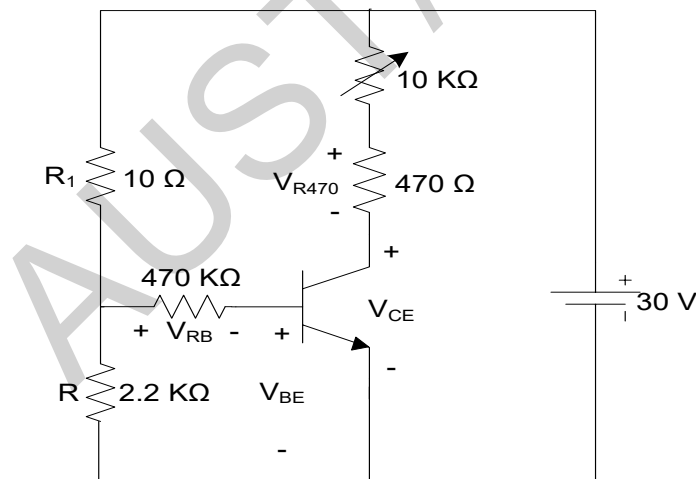

Figure 5.4: Experimental Circuit.

Procedure:

1. Connect the circuit as shown in the figure 5.4. Use 2.2 KΩ as R.
2. Measure V_{RB} and calculate I_S using $I_E = V_{RB} / R_B$. (We will assume that I_B to be constant for a particular setup at input.)
3. Measure the voltages of V_{CE} and V_{R470} . And calculate I_C using $I_C = V_{R470} / R_{470}$.

4. Take at least 10 reading by varying the POT.
5. Repeat step 1 to 4 with resistance R as 3.3 K Ω and 4.7 K Ω .

Table 5.1 : Data for I - V characteristics of transistor.

R (K Ω)	$I_B = V_{RB} / R_B$ (μ A)	V_{CE} (volts)	V_{R470} (volts)	$I_C = V_{R470} / R_{470}$ (mA)
2.2				
3.3				
4.7				

Report:

1. Plot the graph of I_C vs. V_{CE} with necessary details. Show the different regions of operation.
2. Plot a hypothetical output characteristic using PNP transistor.
3. Find β for the three different condition.

Experiment No: 06

Name of the Experiment: The BJT Biasing Circuits.

Objective:

Study of the BJT Biasing Circuits.

Theory:

Biasing a BJT circuit means to provide appropriate direct potentials and currents, using external sources, to establish an operating point or Q-point in the active region. Once the Q-point is established, the time varying excursions of input signal should cause an output signal of same waveform. If the output signal is not a faithful reproduction of the input signal, for example, if it is clipped on one side, the operating point is unsatisfactory and should be relocated on the collector characteristics. Therefore, the main objective of biasing a BJT circuit is to choose the proper Q-point for faithful reproduction of the input signal. There are different types of biasing circuit. However, in the laboratory, we will study only the fixed bias and self bias circuit. In the fixed bias circuit, shown if figure 6.1, the base current I_B is determined by the base resistance R_B and it remains constant. The main drawback of this circuit is the instability of Q-point with the variation of β of the transistor. In the laboratory, we will test the stability using two transistors with different β . In the self bias circuit shown if figure 6.2, this problem is overcome by using the self biasing resistor R_E to the emitter terminal.

Equipments And Components :

Serial no.	Component Details	Specification	Quantity
1.	NPN Transistor	C828, BD135	1 piece each
2.	Resistor	470 Ω , 560 Ω , 220K Ω	1 piece each
3.	POT	10K Ω	1 unit
4.	Trainer Board		1 unit
5.	DC Power Supply		1 unit
6.	Digital Multimeter		1 unit
7.	Chords and wire		as required

Experimental Setup:

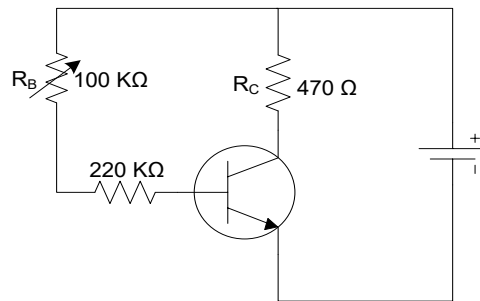

Figure 6.1: Experimental Circuit 1.

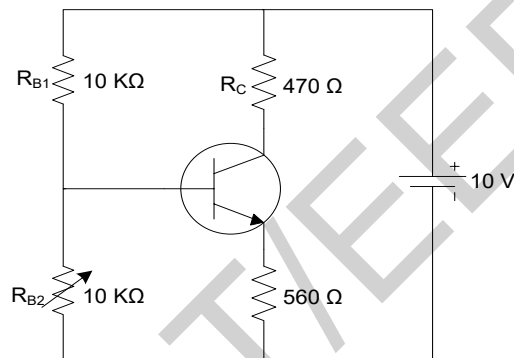

Figure 6.2: Experimental Circuit 2.

Procedure :

1. Arrange the circuit shown in figure - 6.1 by C828. Record R_C and set R_B to maximum value.
2. Decrease POT R_B gradually so that $V_{CE} = V_{CC} / 2$.
3. Measure voltage across R_C and V_{CE} .
4. Record the Q-point (V_{CE} , I_C).
5. Replace the C828 transistor by BD135 and repeat step 3 and 4.
6. Arrange the circuit shown in figure - 6.2 by C828. Record R_C and set R_B to minimum value.
7. Increase POT R_{B2} gradually so that $V_{CE} = V_{CC} / 2$.
8. Measure voltage across R_C and V_{CE} .
9. Record the Q-point (V_{CE} , I_C).
10. Replace the C828 transistor by BD135 and repeat step 8 and 9.

Data Sheet :

Table 6.1 : Data for Fixed Bias Circuit.

Transistor	R_C (Ω)	V_C (volt)	$I_C = V_C / R_C$ (Amp)	V_{CE} (volt)	Q-point
C828					
BD135					

Table 6.2 : Data for Self Bias Circuit.

Transistor	R_C (Ω)	V_C (volt)	$I_C = V_C / R_C$ (Amp)	V_{CE} (volt)	Q-point
C828					
BD135					

Report:

1. Which circuit shows better stability? Explain in the context of the results obtained in the laboratory.
2. Draw the DC load line for both the circuits and show the Q-point.

Experiment No: 07

Name of the Experiment: Frequency Response of a CE (Common Emitter) Amplifier Circuit And Measurement of Input And Output Impedance.

Objective:

Study of the Frequency Response of a CE (Common Emitter) Amplifier Circuit And Measurement of Input And Output Impedance.

Theory:

Frequency response of an amplifier means the range of frequency or the band of frequency within which the gain of the amplifier remains constant. This range of frequency is commonly called the bandwidth of the amplifier. The two corners of the bandwidth are called lower cutoff and higher or upper cutoff frequencies respectively. These are also known as -3dB points. Gain is expressed in dB by the relation of $\text{dB} = 20 \log (\text{gain})$. The output impedance will be measured using Thevenin's Theorem that is if the load impedance is equal to the output impedance then the voltage drop across the load will be half of the open circuit voltage. The input impedance will be measured using Ohm's law.

Equipments And Components:

Serial no.	Component Details	Specification	Quantity
1.	Transistor	C828	1 piece
2.	Resistor	100Ω, 560Ω, 1KΩ, 33KΩ, 100KΩ	1 piece each
3.	POT	10KΩ	1 unit
4.	Capacitor	10 μF, 47 μF	2 pieces, 1 piece
5.	Trainer Board		1 unit
6.	DC Power Supply		1 unit
7.	Oscilloscope		1 unit
8.	Digital Multimeter		1 unit
9.	Chords and wire		as required

Experimental Setup:

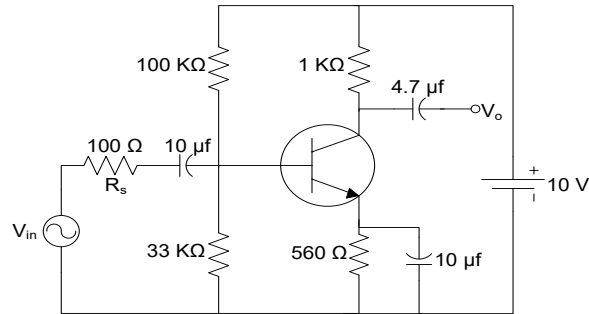

Figure 7.1: Experimental Circuit.

Procedure:

1. Arrange the circuit shown in figure 7.1 and record R_s .
2. Set the amplitude of V_{in} to zero and frequency to 1 KHz.
3. Observe V_o in the oscilloscope. Gradually increase the amplitude of V_{in} up to the maximum undistorted output.
4. Measure the voltage across R_s and V_{in} .
5. Measure output voltage at no load condition. This is V_{oc} .
6. Connect the POT between output node and ground. Adjust the POT so that voltage across it becomes $V_{oc} / 2$.
7. Disconnect the POT and measure its resistance. This is output resistance.
8. Observe V_o and V_{in} in oscilloscope in dual mode. Take the values of V_o and V_{in} for the frequencies specified in the data Table - 7.2.

Data Sheet:

Table 7.1: Data for Fixed Bias Circuit.

V_{in} (volt)	V_{R_s} (volt)	R_s (Ω)	$I_{in} = V_{R_s} / R_s$ (Amp)	$R_{in} = V_{in} / I_{in}$ (Ω)	R_o (Ω)

Table 7.2: Data for Self Bias Circuit.

Frequency, f (Hz)	V_{in} (p-p) (volt)	V_o (p-p) (volt)	Gain = V_o / V_{in}	Gain (dB)
100				
200				
300				
400				
600				
900				
1 K				
2 K				
3 K				
6 K				
10 K				
30 K				
60 K				
80 K				
90 K				
100 K				
200 K				
300 K				
400 K				
500 K				

Report:

1. Draw the gain vs. frequency curve on a semilog paper.
2. Determine the bandwidth from the plot. Also mark the -3dB points on the plot.
3. Compare the input and output impedance of CE (Common Emitter) configuration with CB (Common Base) and CC (Common Collector) configurations. (From Books)

Experiment No: 08

Name of the Experiment: The I - V Characteristics of an N - Channel Enhancement type MOSFET.

Objective:

Study of the I - V Characteristics of an N - Channel MOSFET.

Theory:

The Metal Oxide Semiconductor Field Effect Transistor (MOSFET) is a unipolar, three terminal semiconductor device. A MOSFET is called a unipolar device because the current through it result from the flow of only one of the two kind of charge carrier: electrons or holes. The three terminals of MOSFET are known as Gate (G), Drain (D) and Source (S). The voltage applied to the gate controls the flow of current between drain and source of a MOSFET. In our study we will study the I - V characteristics of an N - channel MOSFET for different values of V_{GS} . For N- channel enhancement type MOSFET V_{GS} is positive (+) and V_{DS} is positive (+). For MOSFET, the positive value of V_{DS} at which the output characteristics enters the saturation region with $V_{GS} \geq V_T$ volt, where V_T is the threshold voltage of MOSFET. An important parameter is pinch off voltage V_p . The value of drain current at which pinch off occurs with $V_{DS} = V_p$ volt is known as I_{DSS} .

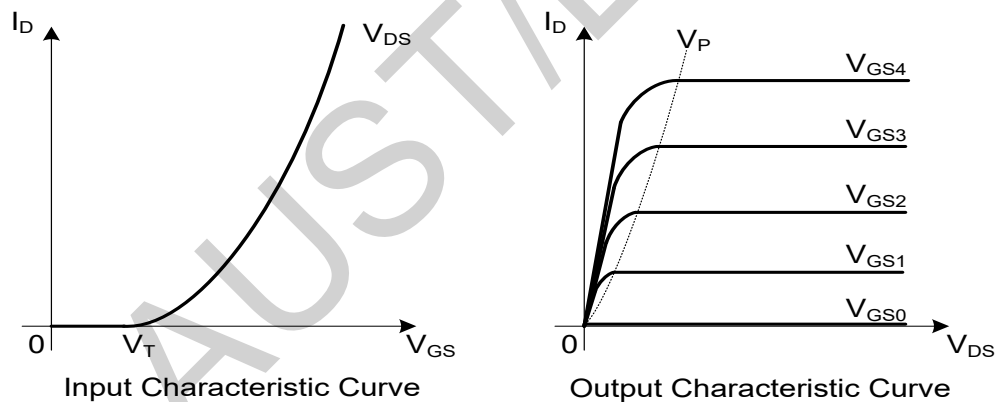

Equipments And Components:

Serial no.	Component Details	Specification	Quantity
1.	MOSFET	2N3819	1 piece
2.	Resistor	1K Ω	1 piece
3.	Trainer Board		1 unit
4.	DC Power Supply		1 unit
5.	Digital Multimeter		1 unit
6.	Chords and wire		as required

Experimental Setup:

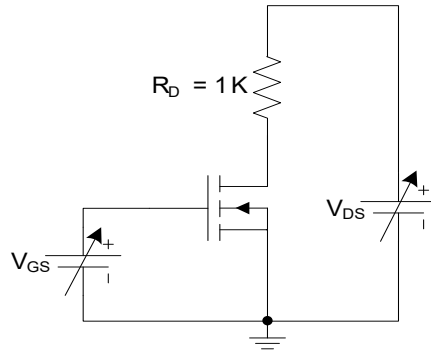

Figure 8.1: Experimental Circuit.

Procedure:

1. Arrange the circuit shown in figure 8.1.
2. Take the reading of V_{DS} and V_R as shown in the data table. The variable voltage source should be varied using fine tuning.

Data Sheet: **Table 8.1:**

V_{GS} (volt)	V_{DS} (volt)	V_R (volt)	$I_{DS} = V_R / R$ (mA)
0			
1			
2			
3			
4			
5			

Report:

1. Plot the I - V characteristics of MOSFET for 6 values of V_{GS} on the graph paper.
2. Is the slopes of both the curves are same in the linear region? Pf not why?
3. Identify the Q-points on the graph paper and mention its value.
4. What is the value of I_{DSS} .